

The San Francisco Billiard Academy

Presents:

A Recognized Instructor Course

Taught by Billiard Congress of America
Certified Instructors

Eric Harada

Bob Jewett

Joseph Meja

What to Teach
How to Teach It
Course Organization

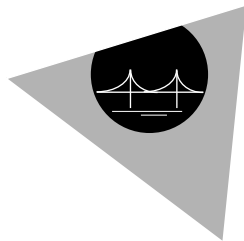

SFBA



B C A

*"What a feeling to shoot better and consistently.
We'll show you the way."*

Recognized Instructor Course

WELCOME

Welcome to the San Francisco Billiard Academy's Recognized Instructors Course. This is the first level of the Billiard Congress of America's Instructor Training Program.

The course is divided into three days of eight sections each which are outlined hour by hour on the following pages. Be sure to take notes and ask questions if you want to get full value from the day's instruction.

At the end of the course, each student will be asked to complete a two-page evaluation sheet and to submit a student feedback form to the Billiard Congress of America (BCA) to rate the quality and professionalism of the SFBA instructors.

Thank you for your participation. We hope that your participation in the Course will be a learning experience of a lifetime. Please feel free to call the instructors with any questions.

Instructors:

Eric Harada harada@sfbilliards.com

Bob Jewett jewett@sfbilliards.com

Joseph Mejia mejia@sfbilliards.com

Instruction is available at billiard rooms throughout the Bay Area and in private facilities by arrangement. Courses include:

- Certified Instructor Course (three days)
- Recognized Instructor Course (three days)
- Introduction to Billiard Instruction (one day)
- Basics Clinic (four to eight hours)
- Nine Ball Clinic (four to eight hours)
- Eight Ball Clinic (four to eight hours)
- Specialized Courses
- Individual Instruction

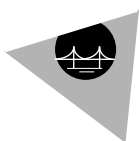

Recognized Instructor Course

Recognized Instructor Course Outline

Day 1

- Hour 1 Welcome
- Hour 2 Review Quiz, Part 1
- Hour 3 Review Quiz, Part 2
- Hour 4 Video Analysis -- Station Demo
- Hour 5 Lunch and Discussion
- Hour 6 Working on Mechanics -- Station Demo
- Hour 7 Presenting Basics I -- Station Demo and Practice
- Hour 8 Q&A, Review, Homework (new quiz questions)

Day 2

- Hour 1 Discuss Homework, Review, Q&A
- Hour 2 Progressive Practice -- Station Demo and Practice
- Hour 3 Presenting Basics II -- Station Demo and Practice
- Hour 4 Teaching Tools
- Hour 5 Lunch and Discussion
- Hour 6 Mechanics, Part 1 -- Checklist
- Hour 7 Video Analysis, Theory and Practice
- Hour 8 Q&A , Review, Homework (study for test, develop flyer)

Day 3

- Hour 1 Review Homework, Publicizing Your Services
- Hour 2 Instruction Formats
- Hour 3 Mechanics, Part 2 -- Drills, Symptoms, Fixes
- Hour 4 Progressive Practices and Other Drills
- Hour 5 Lunch and Discussion
- Hour 6 Review of the Five Stations
- Hour 7 Final Q&A, Review, Test
- Hour 8 Review Test, Feedback Forms

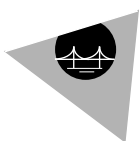

Recognized Instructor Course

Day 1, Hour 1: Welcome and Introductions

SFBA Staff Intro

BCA Instructor Training Program

History

Discussion of levels of certification (App. A2)

Current programs

SFBA History and Programs

Student Intros

Experience

Goals

Course Objectives

Learn basic instructional techniques

Learn basic course structures

Not to learn how to play!

Break

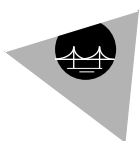

Day 1, Hour 2: Review Quiz Answers, Part 1

Goal: Review quiz to check the Candidate's basic knowledge of billiards.

See Appendix 1 of this handout for questions and answers.

Side Spin

Stance

Simple Physics

Aiming Systems

Break

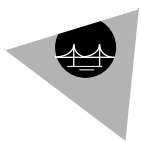

Day 1, Hour 3: Review Quiz Answers, Part 2

Goal: Continue checking candidate's knowledge.

See Appendix 1 for questions and answers.

Half Ball

Banking

Rules

Stroke

Review

Break

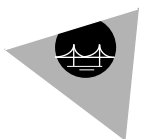

Recognized Instructor Course

Day 1, Hour 4: Video Analysis

Goal: Learn the fundamental of video analysis through demonstration of a basic video session.

See the session handout in the Manual.

Trainer tapes the candidate

Example feedback and analysis

Candidate practices

Example flaws noted during the session:

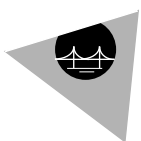

Recognized Instructor Course

Day 1, Hour 5: Lunch and Discussion

Day 1, Hour 6: Working on Mechanics

Goal: Learn how to work on basic mechanics through a example session.

Example handout is in the Manual.

Notes:

Spots drill

One-handed drill

Stroke practice with markers

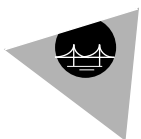

Day 1, Hour 7: Basic Knowledge Demo, Part 1

Goal: Learn clear, efficient ways to present the basics of billiards.

Example handout is in the Manual (App. B5)

Always have the students participate.

Examples:

Tip curvature

Cue straightness

Squirt/deflection

Chalk

Bridges

Left arm

Right arm

Grip

Stroke sequence

Sighting: ghost ball and fractional ball (see following page)

Break

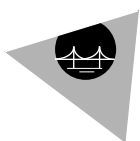

Example Fractional Ball Aiming Handout

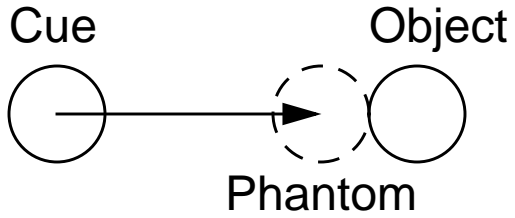

Full ball

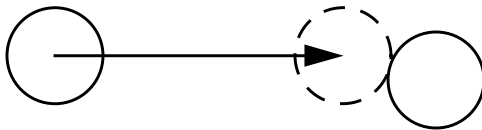
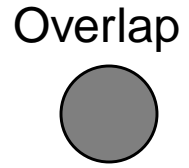

3/4 ball

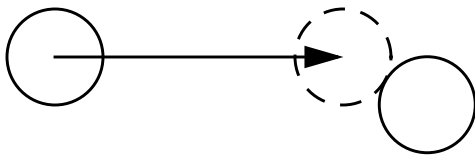
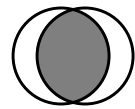

Half ball

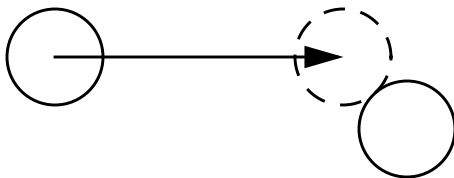
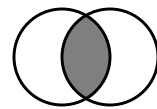

1/4 ball

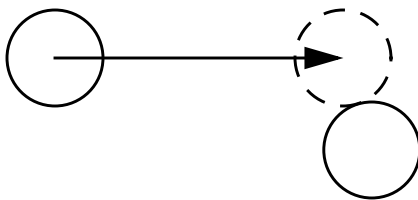
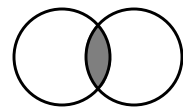

Thin

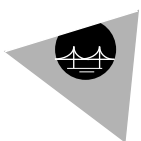
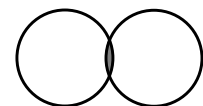

Recognized Instructor Course

Day 1, Hour 8: Q&A, Review, Homework

Goal: Check progress so far and reinforce material

Are there any questions on:

BCA Instructor Program

Course Objectives

Entrance Quiz Items

Video Analysis

Mechanics Training Session

Presenting the Basics, Part 1

Homework:

Prepare four (or more) new questions (with answers) suitable for the entrance quiz.

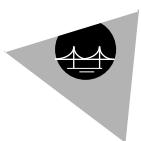

Day 2, Hour 1: Review Homework and Day 1

Goal: Work through candidate's ideas for new quiz questions

Review new quiz questions.

Review of Day 1

Video

Mechanics

Basics I

Break

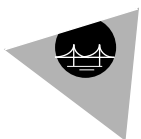

Recognized Instructor Course

Day 2, Hour 2: Progressive Practice Demo

Goal: Learn how to present progressive practice drills through a demonstration session.

Example handout is in Appendix C of the Manual.

Trainer presents session to candidate.

Candidate presents session to trainer.

Break

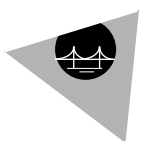

Day 2, Hour 3: Basic Knowledge, Part II

Goal: Learn more demos to illustrate pool basics.

Position Play (App. B5)

Straight shots

Use a stripe to show spin

Angle shots

Straight in the side to make geometry obvious

Mark the rail

Side Spin Shots

Running/reverse -- use a stripe

Example running shot: three cushion position from an easy side pocket shot

Demonstrating the problems:

Miscue

Squirt -- end rail cut

Swerve -- slight masse

Throw -- frozen or close shot

Cling -- chalked balls

Others

Break

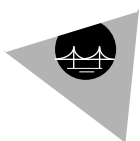

Day 2, Hour 4: Teaching Tools

Goal: Learn to use teaching tools to ease learning

Notes on each item:

Mirror

Laser sight

Practice Balls

Donut stick-ons

Chalk for marking positions

Pendulum

Mirrored ball for bank systems

...

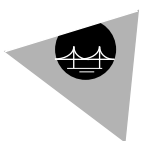

Day 2, Hour 5: Lunch and Discussion

Day 2, Hour 6: Mechanics Theory, Part 1 The Mechanics Checklist

Goal: to understand what mechanics are, why they're important, how to check them, and how to fix them.

What do we mean by *mechanics*?

Importance of good mechanics

Using the "Billiard Rating Sheet" (App B-7)

A Starting Point

Causes and effects

Avoid student overload

Emphasize the points appropriate to the student's level

Highlights From the Checklist

Cradling the cue

Solid bridge

Pendulum technique

Back swing

Straight follow through

Break

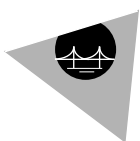

Day 2, Hour 7: Video Analysis, Theory and Technique

Goal: Learn to use video taping to analyze student problems

Motivation

Equipment Considerations

Selecting Shots (App. B-10, diagrams on next page)

Design the setup to look for a specific part of the mechanics

Video Analysis Examples

Hitting the major problems

Positive comments too

Referring back to the checklist (App. B-7)

Video Taping Practice

Break

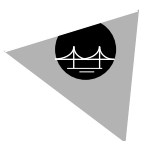

Example Video Positions

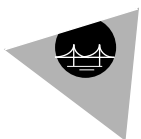
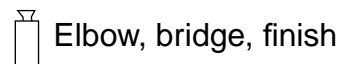
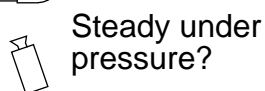
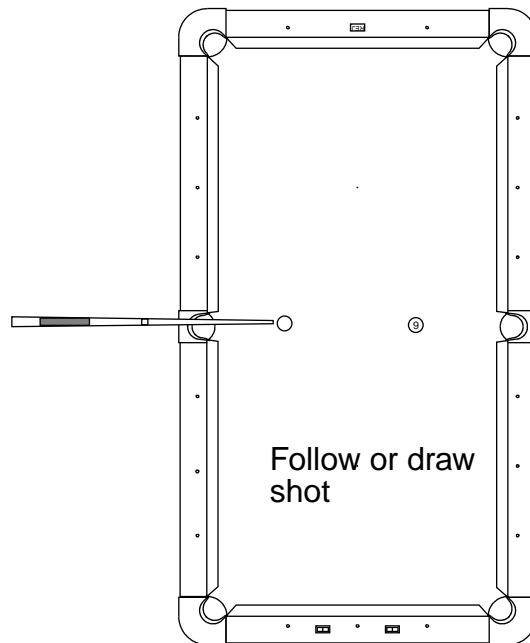
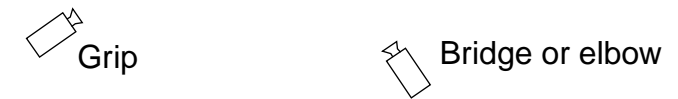
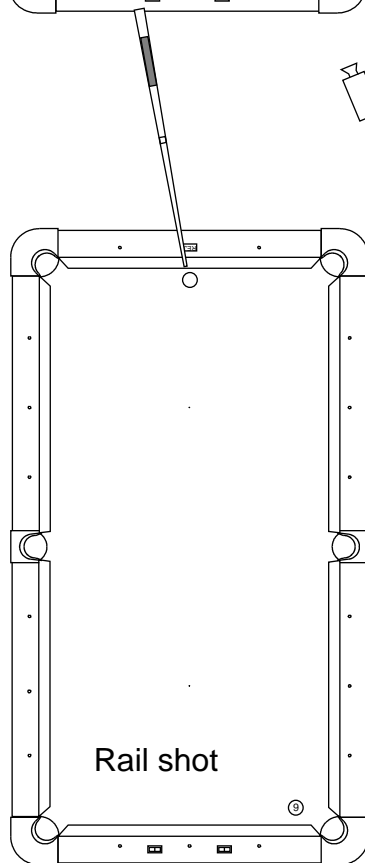
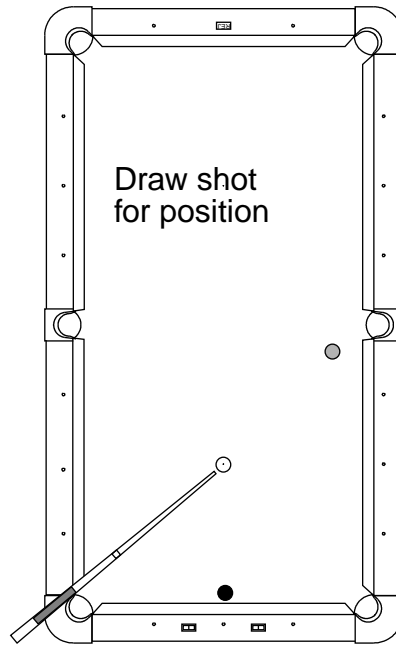
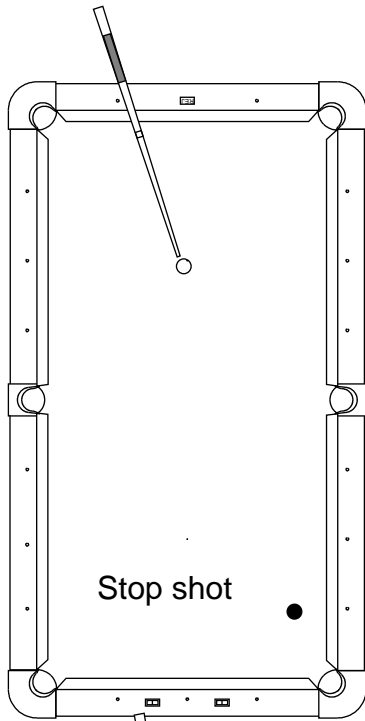

Day 2, Hour 8: Q&A, Review, Homework

Goal: Check and reinforce material learned today

Review:

New quiz questions

Progressive practice demo

Teaching basic position, spin, and bridges

Teaching tools

Mechanics, Part 1

Video Analysis

Homework:

Study for final quiz

Develop an advertizing flyer -- What points must be covered?

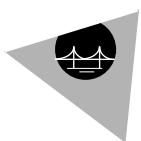

Day 3, Hour 1: Review, Publicizing Your Services

Goal: Learn ways to market your services

Q&A Review

Discussion of candidates' flyers

Discuss section in the Manual

Forming Alliances

Rooms

Leagues

Supply Stores

Break

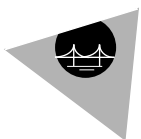

Day 3, Hour 2: Instruction Formats

Goal: Learn some specific lesson formats

Only a Beginning!

Station Format (App. B-3)

Four Week Format (App B-4)

Ten Week Format (next page)

Specialized Courses

Break

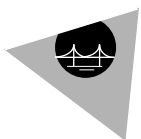

Recognized Instructor Course

Example Format: 10-Week Course

Format: A 10-week course meeting twice a week, perhaps at a college recreation center. One hour (50 minutes) per day.

Level: Beginner

Ratio: One instructor for 10-16 students, two students per table.

The students warm up for the first ten minutes each day to allow for late arrivals. The second ten minutes or so is a mini-lecture on the topic of the day. The remainder of the hour is spent in practice or play with the instructor helping with questions and problems.

Handouts: Course outline, simplified rules of 8 ball, list of references

Week 1 Selecting a cue, chalking, basic open bridge, stance; Basic sighting, rules of 8 ball

Week 2 Speed/stroke drill, rail bridges; Mechanical bridge, closed bridge, playing left handed

Week 3 Follow shots; Draw shots

Week 4 English - benefits; English - pitfalls

Week 5 Stroke practice, margin of error; Throw shots, combinations

Week 6 Kiss shots; Carom shots, the half ball shot

Week 7 Bank shots; Masse and jump shots

Week 8 Care of equipment; Rules of straight pool

Week 9 Rules of 9 ball; Rules of billiards

Week 10 Two days, double elimination 8 ball tournament

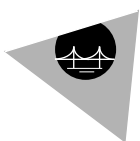

Day 3, Hour 3: Basic Mechanics, Part II

Goals: Learn to use drills to improve mechanics. Learn to diagnose problems and find cures.

Review Practice Drills (App. B-9)

Over the spots

One handed

Standard cueing drill

Symptoms and Fixes

Examples:

Symptom	Problem	Fix
Pump-handle stroke	Misplaced grip	Rubber band
Unintended side spin misses to one side swerve in all strokes	Maybe a dominant position problem	Try to move the head or concentrate on which eye is doing the work
Stick finishes in air	Elbow drops	Over the spots drill, focus on ferrule

Break

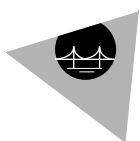

Day 3, Hour 4: Progressive Practice and Other Drills

Goal: Learn to use progressive practice and other drills improve fundamentals and work on specific problems.

Progressive Practice (App. C)

Problems noted during practical test

Main features/characteristics compared to other drills

Working with two students per table

Efficient demonstration when explaining the important parts of the drill

Five Minute Lessons (App. D)

Softly to the side (App. D-3)

Zen draw (App. D-7)

Soft maximum draw (App. D-8)

Other drills and demonstrations

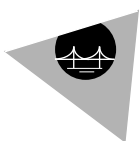

Day 3, Hour 5: Lunch and Discussion

Day 3, Hour 6: Review of Station Format

Goal: Review each of the main sections of a short course on billiard basics.

This will be your final chance in this course to clear up any points on the following sections of the “station” format.

Video Analysis

Mechanics

Progressive Practice

Basics, Part 1

Basics, Part 2

Break

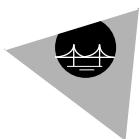

Day 3, Hour 7: Final Q&A, Review, Test

Goal: Clear up any final questions. Test your knowledge.

Review

Other topics:

Jump shots

Systems

Masse

Refereeing

Rules

A selection of games

Mental preparation

Other sections in the Manual

Quiz

Break

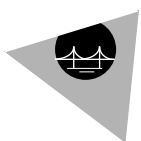

Recognized Instructor Course

Day 3, Hour 8: Wrap-Up

Goal: Receive and give feedback on the course.

Review test answers

Feedback forms

Final discussion

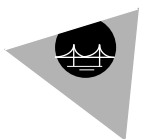

Appendix 1: Quiz Questions and Answers

→Q1. When a shot is played with side spin, several important effects are noticeable and may cause the shot to fail if not included in the planning for the shot. Name three of those effects, describe them, and describe how you demonstrate them to students.

A: *Squirt/deflection.* At the moment the stick hits the ball, the cue ball moves away from tip, almost like a minor miscue. This can be demonstrated by placing the cue ball on the head spot, freezing an object ball to the far end rail, and using extreme english to hit rail first and play the object ball along the rail to the far corner pocket. If played fast with a level stick, the aim is to the wrong side of the object ball with a squirty stick.

Curve/swerve. The cue ball will curve on the way to the object ball. This is accentuated by shooting slow, with draw, plenty of english, and a slightly elevated stick. If the first demo is repeated with this stroke, the cue ball can land on the opposite side of the object ball.

Throw. When the cue ball contacts the object ball, the object ball doesn't travel along the line of centers (the line joining the centers of the two balls at the instant of contact), but moves to the side opposite the english. Place the cue ball about a ball diameter from an object ball and lined up to miss a far corner pocket by about half a diamond. Play straight at the object ball, but with english way out on the equator. The cue ball should stop in place, spinning, while the object ball will either find the hole or miss by a diamond.

Two other minor factors to consider on english shots are "cling" (or "skid") and miscues.

Q2. What are the important factors in cue selection?

A: All parts must be solid. The length, tip diameter and weight must be appropriate for the individual and game played. The most important selection factor is the amount of squirt since cues vary considerably in this and when changing cues or shafts, the squirt must remain nearly constant or english must be relearned.

→Q3. What are the basic goals of the stance (foot, arm, hand, and body position)?

A: The stance must provide a solid, consistent body position that provides a solid support for the cue shaft, free motion of the stroking arm, and accurate sighting. (When stating goals, don't confuse them with specific ways of achieving the goals.)

→Q4. What are some specific parts of a good stance that achieve those goals?

A: The left arm should be as straight as possible to force a constant distance between the bridge hand and the head and to reduce upper body motion. Similarly, a straight back leg reduces variation in the lower body position. The head should position the eyes for accurate sighting, with the eyes centered or with the dominant eye over the shot for players who are not fully binocular.

→Q5. What is the "dominant eye" and how can you test for it?

A: Some players do most of their sighting with only one eye -- the "dominant" eye. A quick test on the pool table is to have the player get in position for a long shot and then use a card to cover first one eye and then the other. If the shot looks a lot different when one eye is covered, that eye is probably the dominant one.

→Q6. What are some symptoms of incorrect eye alignment?

A: Two major symptoms of incorrect eye alignment: 1. A consistent tendency to miss shots to

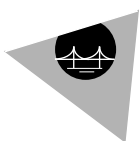

Recognized Instructor Course

one side of the pocket. 2. A swerving of the cue stick side to side on the final stroke. The tip will tend to start to the dominant side and finish on the other side.

Q7. What conditions are necessary for the cue ball to stop dead at the instant it hits an object ball?

Q8. What additional condition is necessary for a stop shot (for the cue ball to remain in position after the instant of impact)?

Q9. Give three common things that cause the cue ball not to stop dead on a stop shot.

A: Judging from the submitted answers, these questions need to be worded more clearly. Q7 asks only about the instant of the collision, and the requirements are that the cue ball hit the object ball squarely, the balls be of the same weight and of good elasticity, like new cast phenolic pool balls. For a stop shot, which concerns what the cue ball does after the instant of contact, the requirement of no follow or draw is added, and of course this probably means that the cue ball started with some draw. Common reasons that stop shots fail are that there is some cut angle, or some follow or draw, or the cue ball is in the air, or the cue ball is either light or heavy, or, as in the case of ivory, the balls are inelastic.

→Q10. Describe the “ghost” or “phantom” ball aiming system.

→Q11. What other systems give equivalent aiming lines?

→Q12. For roughly what length of shot is the simple phantom ball system too inaccurate on a half-ball cut shot?

A: In the “phantom ball” system, you picture the “future” cue ball at the instant it contacts the object ball, with their line of centers going to the center of the pocket. Shoot to make the present cue ball take the place of that future cue ball. (As an aid to visualization, you can have an accomplice temporarily place an object ball in the place of the phantom cue ball.)

Other aiming systems that are equivalent -- that would have you shoot the cue ball to exactly the same place but with different ways of seeing the shot -- include the “inch and an eighth” system, where the target is one ball radius in front of the object ball, the parallel lines system in Mosconi’s book “Winning Pocket Billiards”, and the contact point system in the instruction section of the BCA Rule Book.

While these systems will get the ball somewhere close to the pocket, for some length of shot their neglect of throw renders them too inaccurate to pocket the ball. Q12 asks at what length of shot does the system fail if it is executed with perfect accuracy and mechanics. The surprising answer is that even with generous pockets, the system starts failing for shots only a diamond and a half from the pocket.

Q13. What is required to get a lot of draw on the cue ball?

A: The cue ball must be struck low and hard.

Q14. What is recommended but not actually required for lots of draw?

A: While not actually required for draw, several other stroke qualities will help gain consistency: 1. Follow through. 2. Level stroke, especially on fast shots. 3. A firm, closed bridge.

Many other ideas have been suggested, such as a loose or firm grip, snapping the stick back as quickly as possible, transferring weight to the back foot, etc., but these have little, if any, basis in fact.

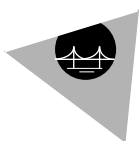

Recognized Instructor Course

Q15. Describe some situations in which side spin is required to make a shot (not counting position requirements).

A: 1. When not enough of the ball can be struck directly to get the angle to the pocket. Example: spot (about) three balls and make the back one directly into a corner pocket.

2. When the angle of a bank must be adjusted with either running or reverse english on the object ball.

3. When a kick shot angle must be adjusted.

4. When a 90-degree cut of a ball on the rail is needed.

Q16. In damp conditions or on dirty cloth, draw dissipates rapidly. Why?

A: About half of the respondents got this exactly backwards, saying that such conditions reduce friction. In fact dirt, such as powder from chalk, and humidity increase the friction between the ball and the cloth, causing the draw to be rubbed off faster.

Here's a quick experiment you can try: wax the cue ball. I once asked a friend if he could make a length-of-the-table stop shot on old cloth. He kept drawing the cue ball back to the middle of the table until he realized that the secretly waxed cue ball was making the felt play like slippery new. Wax also helps when you're practicing masse shots on old cloth.

→Q17. Describe aiming a half-ball shot. Neglecting throw, what is the cut angle for a half-ball shot?

This question tripped up most of those who tried it. They got the description right: the axis of the cue stick points through the center of the cue ball directly to the edge of the object ball. But they said it is a 45 degree cut when it is 30 degrees. (Imagine three balls all touching in a triangle, and recall equilateral triangles from high school geometry.) Including friction, the cut angle is slightly less than 30 degrees.

→Q18. Describe the simple "mirror system" for shooting bank shots, and at least three methods of lining shots up for that system.

A: This system assumes that the rails act like perfect mirrors and the balls are reflected like rays of light. These systems are equivalent, in that within the accuracy inherent in the method, the calculate the "mirror" line:

1. The method in Mosconi's Winning Pocket Billiards in which four lines including two perpendiculars are drawn to find the rail target point.

2. Counting diamonds for each end of a line passing through the center of the object ball and adjusting the line until the two ends are in a ratio of 1:2.

3. Constructing a "mirrored pocket" by taking a distance of a table width (or length, for long banks) past the banking rail, giving the point where the pocket would appear in a mirror on the banking rail.

→Q19. Give three situations in which the simple mirror system is not accurate enough to aim bank shots.

A: When shot hard, when english must be used, and when, on a soft shot at about 45 degrees, the ball has time to acquire follow before striking the rail.

Q20. How large is a pool ball?

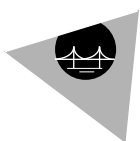

Recognized Instructor Course

Q21. With what tolerance?

A: The specifications are on page 7 of the rule book [BCA, p7]. 2.25 inches within 5/1000 inches.

Q22. Approximately what fraction of pool balls are not within tolerance?

A: The allowed variation is five thousandths of an inch, and most pool balls fail. They're mostly OK fresh from the factory, but wear down in play and are illegally small within a year or two. This is most noticeable for the cue ball which gets much more wear than any object ball. The common symptom is great draw but lousy follow because the cue ball bounces back from the larger, heavier object balls.

Q23. How large is the playing surface on 4' x 8' and 41x2' x 9' tables, and how is it measured?

A: See BCA, p6. Note that there are two sizes of 4x8. Measurement is between the noses of the cushions.

Q24. What is the required thickness of slate?

A: A "commercial" table must have at slate at least one inch thick. [BCA p7]

Q25. What are the allowed weight and dimensions of a cue stick?

A: There is no specific rule for cue stick dimensions.

Q26. What is the grace period before a match is forfeited for lateness?

A: Fifteen minutes [Rule 1.6]

Q27. What should a referee do prior to a match?

A: He will ensure that the table is ready for play, including cleanliness, chalk, bridges, table markings, etc. [Rule 2.6]

→Q28. Is a "split hit," that appears to have been simultaneous contact on both a legal and an illegal object ball, a foul?

No, it is a legal shot. [Rule 1.16.5]

Q29. At 9-ball, a player is stroking, about to shoot the 4 ball. A spectator shouts out, "Shoot the 3!" What should the referee do?

A: The spectator should be removed from the playing area. [Rule 2.24]

Q30. Is a miscue a foul?

A: Maybe. On a jump shot any miscue is a foul, even if the other requirements of the shot are met. On other shots, miscues are not fouls, unless maybe the ferrule touches the cue ball on the miscue.

→Q31. At 9-ball, when does an object ball spot?

A: When the nine is pocketed illegally or driven off the table, it spots. Other balls do not spot. [Several rules on page 54.]

Q32. At 9-ball, a player plays the 1-7 combination, pockets the 7, but the 1 ball goes off the table. What happens?

A: It is a foul, the 1 and 7 remain off the table, and the opponent gets ball in hand. [Rule 5.10]

Q33. A player "pushes out" with the side of his stick, and is warned not to do so. Is there any

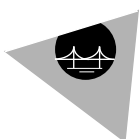

Recognized Instructor Course

penalty, and does it change for a second offense?

A: It is a foul. A second intentional occurrence results in forfeiture of the match. [Rule 3.28]

Q34. When calling a shot at 8-ball, what must be specified besides the ball and the pocket?

A: Nothing. [Rule 4.2]

Q35. On an open break, how many balls must be driven to the rail if no ball is pocketed?

A: Four. [See individual game rules.]

Q36. What is the penalty at 8-ball for failure to make an open break?

A: The opponent may shoot from the position, or have a new break with choice of breaker. [Rule 4.6]

Q37. What is the penalty at 9-ball?

A: Cue ball in hand. [Rule 5.3]

Q38. With ball in hand after a scratch on the break, what are the restrictions on cue ball placement at 9-ball?

A: The cue ball must be placed on the playing surface and not in contact with any object ball. [Rules 3.21, 5.9]

Q39. At 8-ball?

A: The cue ball must be placed above the headstring. [Rule 4.7]

Q40. Give four examples of how a player can foul during the other player's inning.

A: 1. By causing any ball to move. [Rule 3.40] 2. By distracting the shooter. [Rule 3.40] 3. By shooting a practice shot. [Rule 1.8] 4. By getting outside assistance. [Rule 2.23]

Q41. At 14.1, a player fails three times in a row to drive two balls to the rail on the opening break shot. What is the score after those three strokes?

A: Negative six to zero. Breaking violations are not part of the three foul sequence. [Rule 6.6]

→Q42. What happens if a player unscrews his jointed cue stick?

A: If the opponent is at the table, it is considered to be a concession of the match. [Rule 1.14]

Q43. While playing a bank shot, the player places the chalk where he wants to hit on the rail, then shoots. Is that a foul?

A: This is slightly a trick question. In the 1993 Rule Book, it was only forbidden by the general sanction against using equipment in an unusual manner. In the 1994 Rule Book, there is Rule 3.42, which reads in part, "Illegal Marking. If a player intentionally marks the table in any way ... he has fouled."

→Q44. Describe a push shot.

A: At pool it is a shot in which the cue stick is brought up nearly in contact with the cue ball and then is gradually accelerated. This contrasts with a normal shot in which the cue stick has nearly its peak speed when it contacts the cue ball.

Q45. What is the specific criterion used to judge double hits, when the cue starts very close to the object ball?

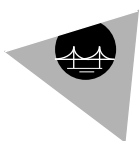

Recognized Instructor Course

A: If the cue ball penetrates into the original space of the object ball more than 1/2 ball diameter, the referee is directed to call a foul unless the shot can be positively determined not to have been a foul. [Rule 2.20]

Q46. If a ball stops at the brink of a pocket, how long is it given to drop before it is considered not to have been pocketed?

A: Five seconds. [Rule 3.30]

Q47. May either player inspect the rack prior to the break?

A: Not if a referee is racking. [Rule 2.7]

Q48. If the cue ball is frozen to the object ball, what sort of stroke is permitted towards that ball?

Any normal stroke is permitted. [Rule 3.22]

Q49. At 8-ball, what happens if the 8 is pocketed on the break?

A: The breaker may break again or chose to shoot from the position after the eight is spotted. If the break was a foul, the incoming player has the same choices. [Rule 4.9]

Q50. What happens in 9-ball if the 9 goes on the break?

A: With no foul, the breaker wins. With a foul, it spots and the opponent gets ball in hand. [Rule 5.3]

Q51. At 8-ball, a player calls safe and then pockets an easy, obvious shot. What happens?

A: It is the other player's turn from the position left, if no foul occurred.

Q52. What happens at 9-ball for the same situation?

A: The same player must shoot. There is no called safety in nine ball.

Q53. At 9-ball, the player pockets the 9, and cue ball is rolling slowly up the table towards the middle of the end rail. The player picks the cue ball up while it is barely moving and places it for the next break. Has he fouled?

A: Yes. [Rule 3.14] This rule is often violated by ignorant players, and the referee should use caution in its application since players don't like to have their ignorance demonstrated.

